

Li+ Charger Protection IC

Features

- Provide OUT Pin 5V Voltage Clamping Protection
- Thermal Charging Regulation Protection
- Provide Input Over-voltage Protection
- Provide Input Over-current Protection
- Provide Over Temperature Protection
- Provide Reverse Current Blocking
- High Immunity of False Triggering
- High Accuracy Protection Threshold
- Low On Resistance 0.75W Typ.
- Compact TDFN2x2-8 and DFN3x3-8 Packages
- Lead Free and Green Devices Available (RoHS Compliant)

Applications

- Cell Phones

Pin Configuration

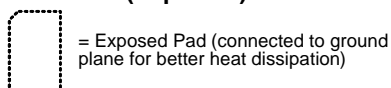
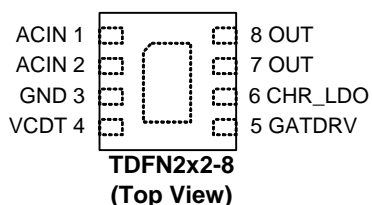
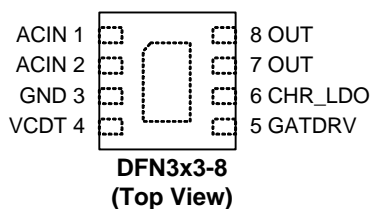

General Description

The APL3218 provides complete Li+ charger protection against Input over-voltage, input over-current and over-temperature. When any of the monitored parameters is over the threshold, the IC turns off the charging current. All protections also have deglitch time against false triggering due to voltage spikes or current transients.

The APL3218 integrates a 5.5V LDO to prevent ACIN overshoot reaching CHR_LDO and OUT. When any transient peak voltage above 5.5V presenting in ACIN pin, but below OVP threshold, the internal LDO will clamp its output at 5.5V. When ACIN voltage exceeds OVP threshold, the device will turn off charging current. The charging current is controlled by the GATDRV pin. When sourcing a current from the GATDRV pin, the OUT pin delivers the charging current which is 200-fold magnified in amplitude based on GATDRV's current.

Other features include accurate V_{VCDT}/V_{ACIN} Voltage divider, reverse current blocking from OUT to ACIN and OTP protection. The APL3218 provides complete Li+ charger protections, and saves the external MOSFET and Schottky diode for the charger of cell phone's PMIC. The above features and small package make the APL3218 an ideal part for cell phones applications.

Simplified Application Circuit

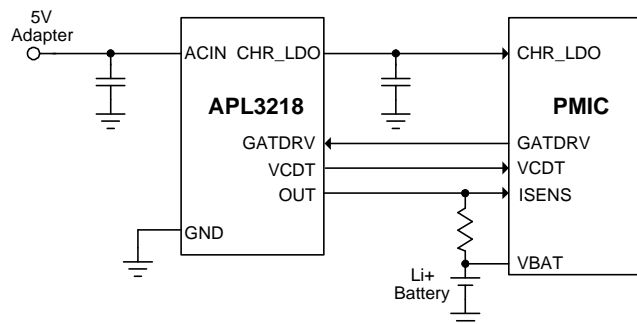

ANPEC reserves the right to make changes to improve reliability or manufacturability without notice, and advise customers to obtain the latest version of relevant information to verify before placing orders.

Ordering and Marking Information

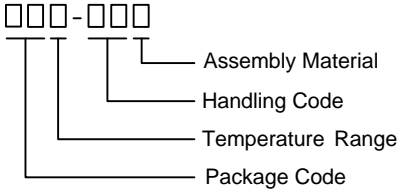
<p>APL3218 □□□-□□□</p>  <p> Assembly Material Handling Code Temperature Range Package Code </p>	<p>Package Code QB : TDFN2x2-8 QA : DFN3x3-8 Operating Ambient Temperature Range I : -40 to 85 °C Handling Code TR : Tape & Reel Assembly Material G : Halogen and Lead Free Device</p>
<p>APL3218 QB: L18 • X</p>	<p>X - Date Code</p>
<p>APL3218 QA: APL 3218 • XXXXX</p>	<p>X - Date Code</p>

Note: ANPEC lead-free products contain molding compounds/die attach materials and 100% matte tin plate termination finish; which are fully compliant with RoHS. ANPEC lead-free products meet or exceed the lead-free requirements of IPC/JEDEC J-STD-020D for MSL classification at lead-free peak reflow temperature. ANPEC defines “Green” to mean lead-free (RoHS compliant) and halogen free (Br or Cl does not exceed 900ppm by weight in homogeneous material and total of Br and Cl does not exceed 1500ppm by weight).

Absolute Maximum Ratings (Note 1)

Symbol	Parameter	Rating	Unit
V _{ACIN}	ACIN Input Voltage (ACIN to GND)	-0.3 ~ 20	V
V _{CHR_LDO}	CHR_LDO to GND Voltage	-0.3 ~ 7	V
V _{GATDRV}	GATDRV to GND Voltage	-0.3 ~ V _{CHR_LDO}	V
V _{CDT}	VCDT to GND Voltage	-0.3 ~ 7	V
V _{OUT}	OUT to GND Voltage	-0.3 ~ 7	V
I _{OUT}	Output Current (OUT to GND)	1.5	A
T _J	Maximum Junction Temperature	150	°C
T _{STG}	Storage Temperature	-65 ~ 150	°C
T _{SDR}	Maximum Lead Soldering Temperature (10 Seconds)	260	°C

Note 1: Stresses beyond those listed under “absolute maximum ratings” may cause permanent damage to the device. These are stress ratings only and functional operation of the device at these or any other conditions beyond those indicated under “recommended operating conditions” is not implied. Exposure to absolute maximum rating conditions for extended periods may affect vice reliability.

Thermal Characteristic

Symbol	Parameter	Typical Value	Unit
θ _{JA}	TDFN2x2-8 Junction-to-Ambient Resistance in free air <small>(Note 2)</small>	75	°C/W
θ _{JA}	DFN3x3-8 Junction-to-Ambient Resistance in free air <small>(Note 2)</small>	65	°C/W

Note 2: θ_{JA} is measured with the component mounted on a high effective thermal conductivity test board in free air. The exposed pad of TDFN2x2-8 is soldered directly on the PCB.

Recommended Operating Conditions (Note 3)

Symbol	Parameter	Range	Unit
V_{ACIN}	ACIN Input Voltage	4.5 ~ 9	V
I_{OUT}	Output Current	0 ~ 0.7	A
T_A	Ambient Temperature	-40 ~ 85	°C
T_J	Junction Temperature	-40 ~ 125	°C
C_{CHR_LDO}	CHR_LDO Output Capacitor	1	μF

Note 3: Refer to the typical application circuit

Electrical Characteristics

Unless otherwise specified, these specifications apply over $V_{ACIN}=5V$, $T_A = -40 \sim 85$ °C. Typical values are at $T_A=25$ °C.

Symbol	Parameter	Test Conditions	APL3218			Unit
			Min.	Typ.	Max.	
ACIN INPUT CURRENT and POWER-ON-RESET (POR)						
I_{ACIN}	ACIN Supply Current	$I_{OUT}=0A$, CHR_LDO and GATDRV open	-	350	600	μA
V_{POR}	ACIN POR Threshold	V_{ACIN} rising	2.4	2.6	2.8	V
	ACIN POR Hysteresis		-	250	-	mV
$T_{B(ACIN)}$	ACIN Power-On Blanking Time		-	8	-	ms
INTERNAL SWITCH ON RESISTANCE						
	ACIN to OUT On Resistance	$I_{OUT} = 0.7A$	-	0.75	-	Ω
	CHR_LDO Discharge Resistnace	$V_{ACIN} = 12V$, $V_{CHR_LDO} = 2V$	-	500	-	Ω
INPUT OVER-VOLTAGE PROTECTION (OVP)						
V_{REG}	Internal LDO Output Voltage	$V_{ACIN} = 7V$, $I_{OUT} = 10mA$, $T_J = -40 \sim 125$ °C	5.225	5.5	5.775	V
	CHR_LDO Output Series Resistance		2.4	3	3.6	kΩ
V_{OVP}	Input OVP Threshold	V_{ACIN} rising, $T_J = -40 \sim 125$ °C	9.5	10	10.5	V
	Input OVP Hysteresis		-	200	-	mV
T_{OVP}	Input OVP Propagation Delay		-	-	1	μs
$T_{ON(OVP)}$	Input OVP recovery time		-	1	-	ms
OVER-CURRENT PROTECTION (OCP)						
I_{OC}	Over-Current Trip Threshold	$T_J = 25$ °C	1.05	1.5	1.95	A
I_{CL}	Current Limit Level	$T_J = 25$ °C	0.84	1.2	1.56	A
VCDT INTERNAL DIVIDER						
	Divider Ratio	V_{VCDT}/V_{ACIN}	0.1035	0.1056	0.1078	V/V
CHARGE CURRENT CONTROL						
	Current Mirror Gain	$I_{OUT} = 0.6A$, I_{OUT}/I_{GATDRV}	100	200	300	A/A
REVERSE CURRENT BLOCKING						
	PMOS Lockout Threshold		-	20	-	mV
	PMOS Lockout Release Threshold		-	100	-	mV
	OUT Input Current (Reverse Current Blocking)	$V_{ACIN} = 0V$, $V_{OUT} = 4.2V$, $V_{GATDRV}=0V$	-	-	1	μA

Electrical Characteristics (Cont.)

Unless otherwise specified, these specifications apply over $V_{ACIN}=5V$, $T_A = -40 \sim 85$ °C. Typical values are at $T_A=25$ °C.

Symbol	Parameter	Test Conditions	APL3218			Unit
			Min.	Typ.	Max.	
OUT OVERSHOOT CLAMP						
V_{CLAMP}	Overshoot Clamp Rising Threshold	V_{OUT} rising slew rate $> 0.2V/\mu s$	4.6	-	5.2	V
	Overshoot Clamp Pull Low Resistance	V_{OUT} rising slew rate $> 0.2V/\mu s$	-	3	-	Ω
	Overshoot Clamp Active Time	From Overshoot Clamp Threshold being surpassed	-	150	-	μs
THERMAL SHUTDOWN PROTECTION						
T_{OTP}	Thermal Shutdown Threshold	T_J rising	-	160	-	°C
	Thermal Shutdown Hysteresis		-	40	-	°C

Typical Operating Characteristics

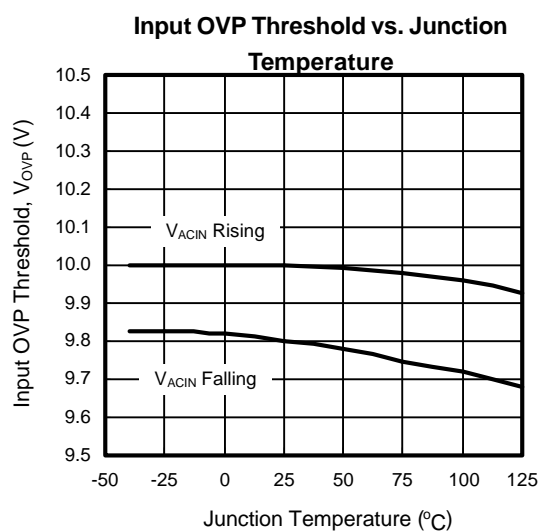
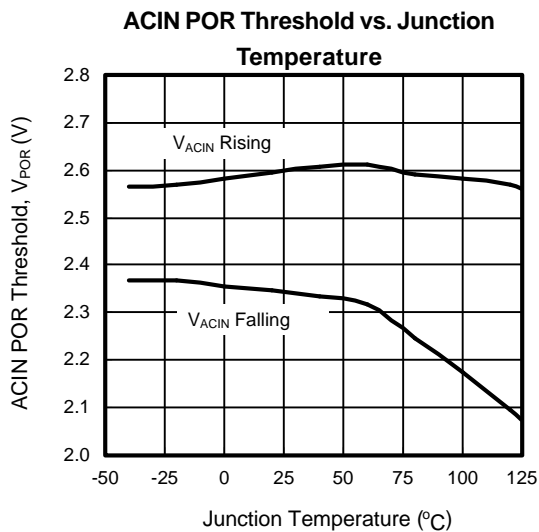
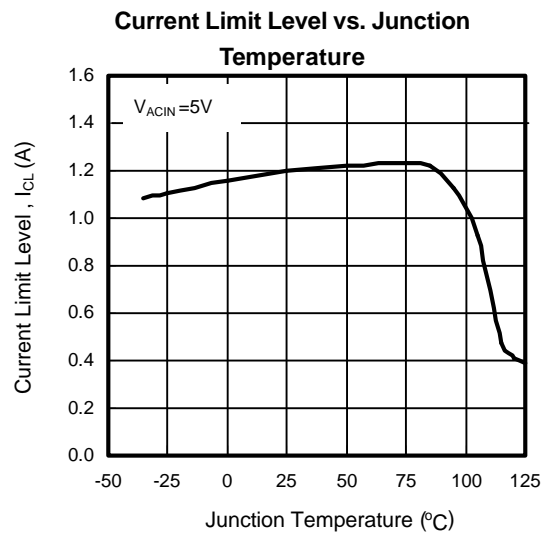
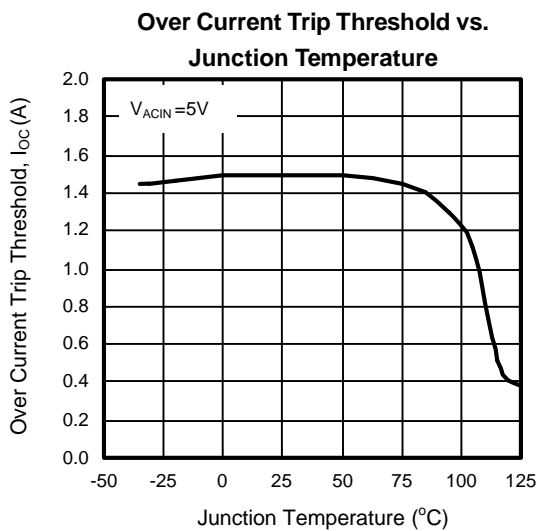
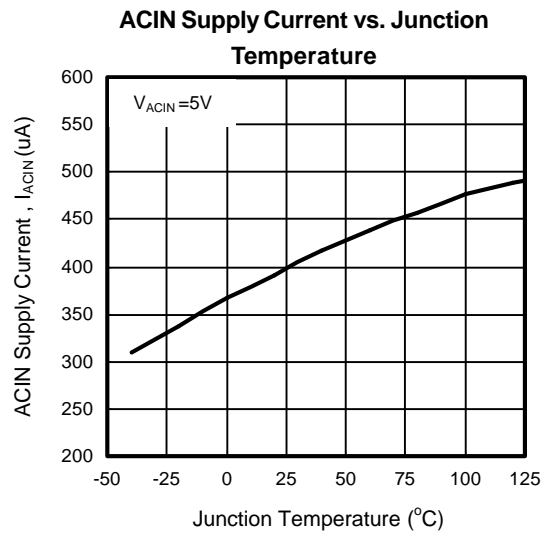
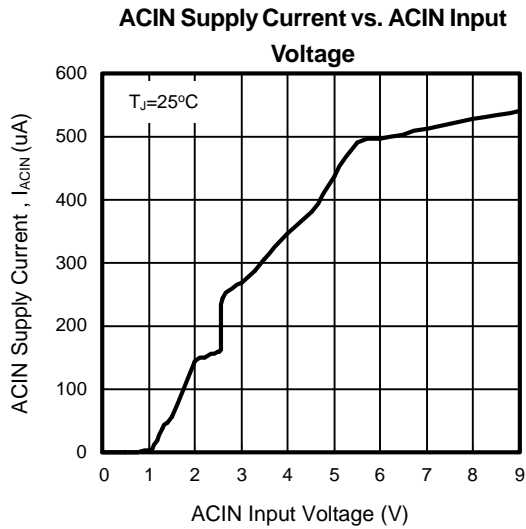

Typical Operating Characteristics

Current Mirror Gain vs. Junction Temperature

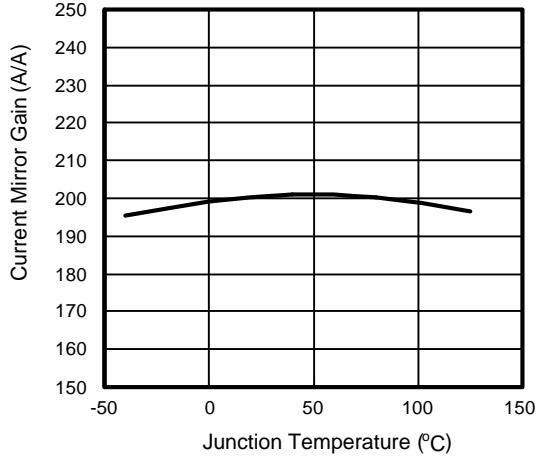

LDO Mode Voltage vs. Junction Temperature

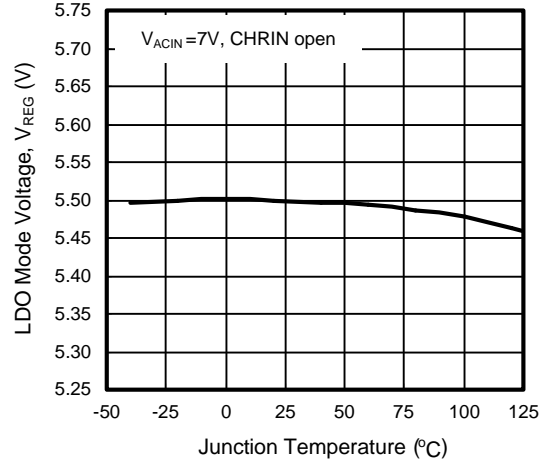

ACIN to OUT On Resistance vs. Junction Temperature

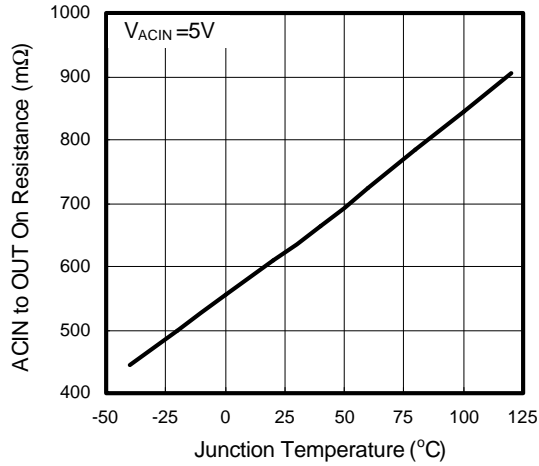

Operating Waveforms

Refer to the typical application circuit. The test condition is $V_{IN}=5V$, $T_A=25^\circ C$ unless otherwise specified.

Normal Power On

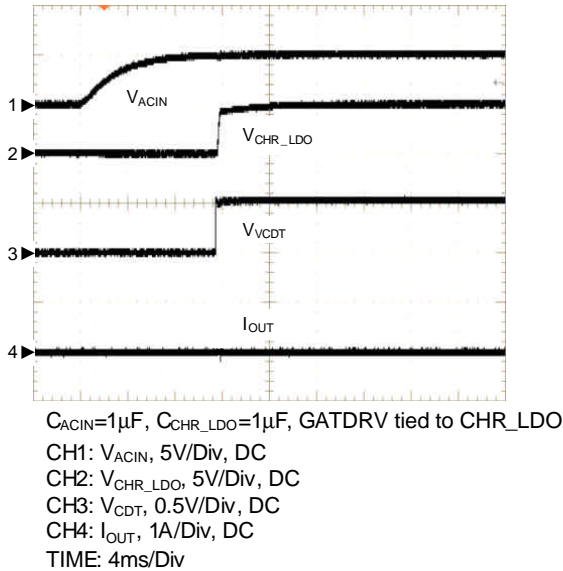

Power On into OVP Protection

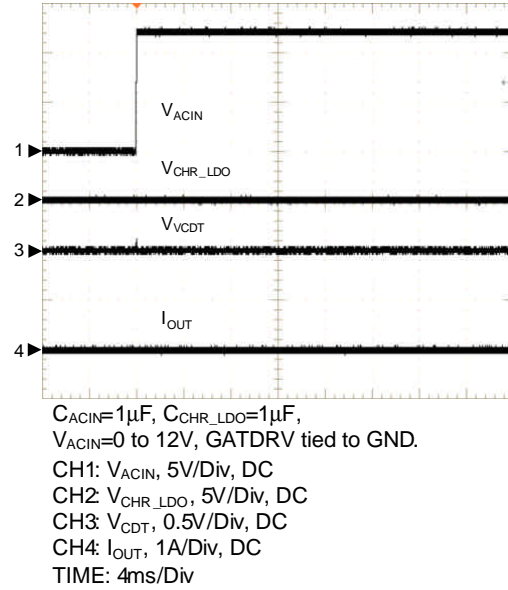

Input Over-Voltage Protection

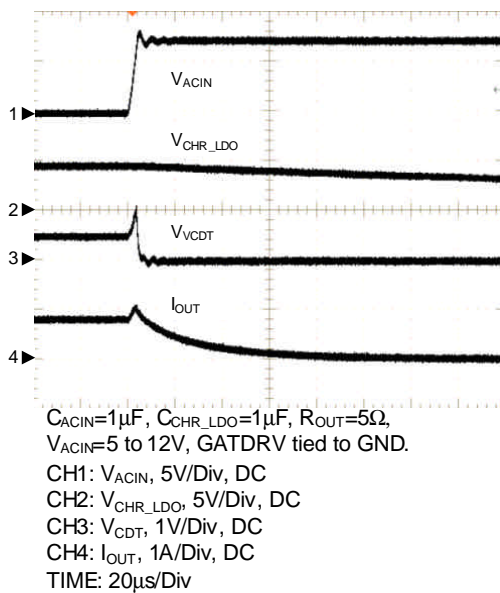

Recovery from Input OVP

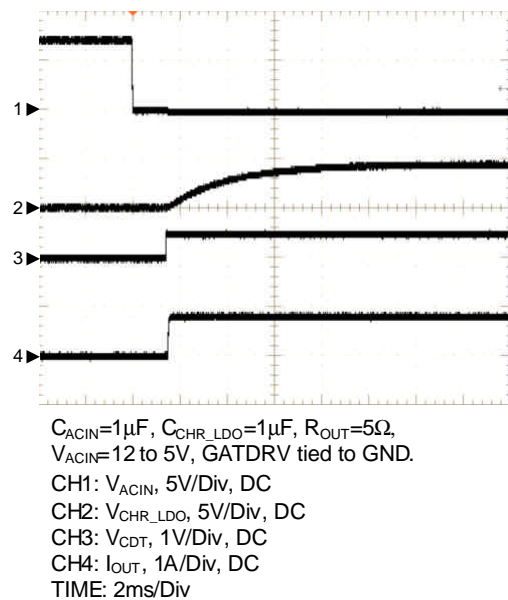

Operating Waveforms

Refer to the typical application circuit. The test condition is $V_{IN}=5V$, $T_A=25^{\circ}C$ unless otherwise specified.

Current Limit Protection

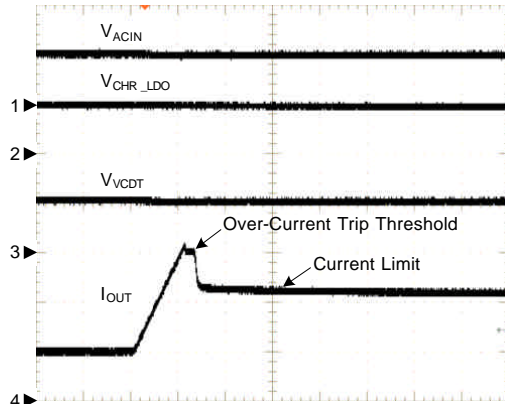

$C_{ACIN}=1\mu F$, $C_{CHR_LDO}=1\mu F$, $I_{OUT}=0.5A$ to $1.6A$
 GATDRV tied to GND.
 CH1: V_{ACIN} , 5V/Div, DC
 CH2: V_{CHR_LDO} , 5V/Div, DC
 CH3: V_{CDT} , 0.5V/Div, DC
 CH4: I_{OUT} , 0.5A/Div, DC
 TIME: 200 μs /Div

Input Line Transient Response

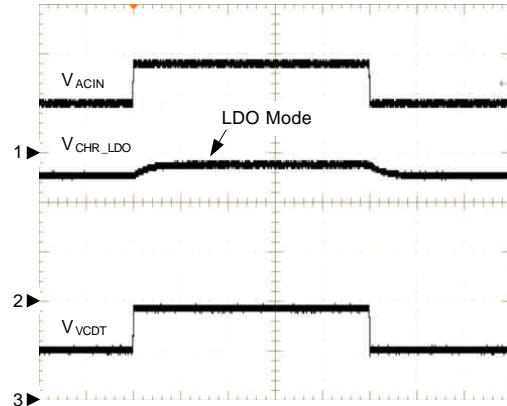

$C_{ACIN}=1\mu F$, $C_{CHR_LDO}=1\mu F$, $V_{ACIN}=5V$ 9V 5V.
 CH1: V_{ACIN} , 5V/Div, DC
 CH2: V_{CHR_LDO} , 2V/Div, DC
 CH3: V_{CDT} , 0.5V/Div, DC
 TIME: 10ms/Div

Pin Description

PIN		FUNCTION
NO	NAME	
1	ACIN	Power Supply Input. Connect this pin to external DC supply. Bypass to GND with a 1 μ F (minimum) ceramic capacitor.
2		
3	GND	Ground terminal.
4	VCDT	Provide an interval voltage divider. This pin divides ACIN voltage into 39/369 ratio.
5	GATDRV	Charging current control pin. When sourcing a current from this pin, the OUT pin will source out a current whose magnitude is $200 \times I_{GATDRV}$.
6	CHR_LDO	Output Pin. The pin provides supply voltage to the PMIC input. Bypass to GND with a 1 μ F (minimum) ceramic capacitor.
7	OUT	Output Pins. The pin provides supply source current in series with a resistor to battery.
8		This pin possesses the overshoot clamp function to limit peak voltage.
Exposed Pad	-	Exposed Thermal Pad. Must be electrically connected to the GND pin.

Block Diagram

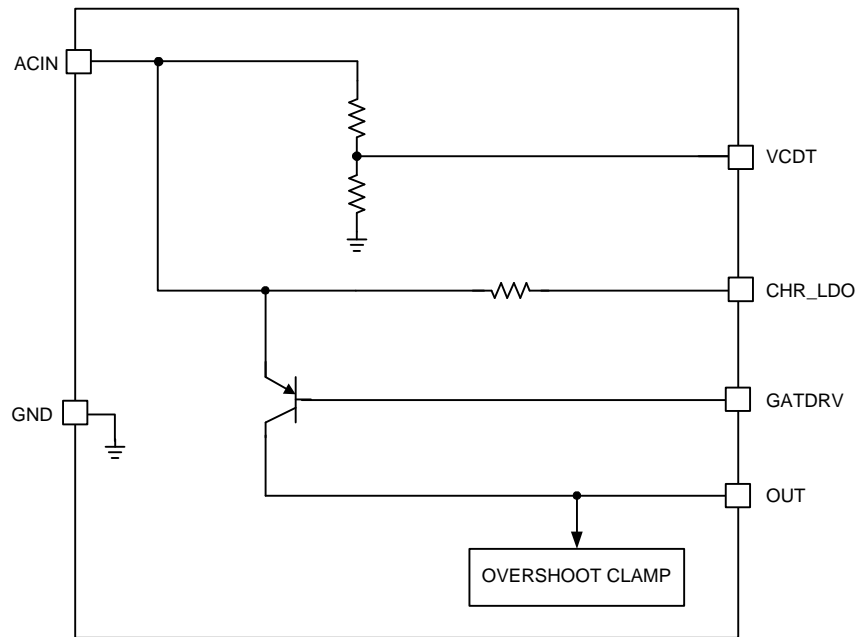

Typical Application Circuit

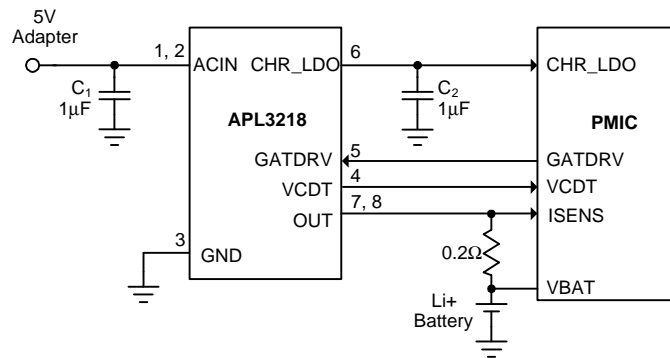

Designation	Description
C _{ACIN}	1µF, 25V, X5R, 0603 Murata GRM188R61E105K
	1µF, 16V, X5R, 0603 Murata GRM188R61C105K
C _{CHR_LDO}	1µF, 6.3V, X5R, 0603 Murata GRM185R60J225KE26

Function Description

ACIN Power-On-Reset (POR)

The APL3218 is built-in a power-on-reset circuit to keep the output shut off until internal circuitry is operating properly. The POR circuit has hysteresis and a de-glitch feature so that it will typically ignore undershoot transients on the input. When input voltage exceeds the POR threshold and after 8ms blanking time, the output voltage starts a soft-start to reduce the inrush current.

ACIN Over-Voltage Protection (OVP) and LDO Mode Operation

The CHR_LDO output of the IC operates similar to a linear regulator. When the ACIN input voltage is less than V_{REG} , and above the ACIN POR V_{ACIN} , the internal LDO output voltage tracks the input voltage with a voltage drop caused by $R_{DS(on)}$ of MOSFET Q1. When the ACIN input voltage is greater than V_{REG} plus the $R_{DS(on)}$ drop of Q1, and less than V_{OVP} , the internal LDO output voltage is regulated to V_{REG} , and this is also referred as LDO mode operation. If the input voltage rises above V_{OVP} , the internal FET Q1 and Q2 will be turned off within 1 μ s to protect connected system on OUT pin. When the input voltage returns below the input OVP threshold minus the hysteresis, the FETs is turned on again after 1ms recovery time. The input OVP circuit has a 200mV hysteresis and a recovery time of $T_{ON(OVP)}$ to provide noise immunity against transient conditions.

Charging Current Control

The charging current is controlled by the GATDRV pin. When sourcing a current from the GATDRV pin, the OUT pin delivers the charging current which is 200-fold magnified in amplitude based on GATDRV's current. The I_{OUT} current can be calculated by this following equation:

$$I_{OUT} = 200 \times I_{GATDRV}$$

where

The I_{OUT} is the current flowing out from OUT pin.

The I_{GATDRV} is the current flowing out from GATDRV pin.

Current Limit

The output current is monitored by the internal current limit circuit. When the output current reaches the current limit threshold, the device limits the output current at current limit threshold. The current limit level decrease as the junction temperature increase. When the Junction temperature increases, the internal current limit circuit reduces the current limit level, allowing the device's Junction temperature to cool down. (See Figure 1)

Internal P-MOSFET and Reverse Current Blocking

The APL3218 integrates a P-channel MOSFET with the body diode reverse protection to replace the external PNP transistor and Schottky diode for cell phone's PMIC. The body diode reverse protection prevents battery voltage supplies to CHR_LDO and ACIN pin. When the P-channel MOSFET's negative V_{SD} voltage is detected, the internal bulk selection circuitry will switch the body diode of the P-channel MOSFET forward biased from source to drain, meanwhile the P-channel is turned off regardless of GATDRV's current. This after the detection of negative V_{SD} , the P-channel MOSFET is in lockout state to prevent battery discharging from ACIN and CHR_LDO to external circuitry. The P-channel MOSFET lockout will be releases when positive V_{SD} is detected.

OUT Overshoot Clamp

This OUT pin possesses the overshoot clamp function to limit peak voltage. Since the clamping function needs a low resistance path between OUT pin and external high voltage source (in abnormal condition), please connect this OUT pin directly to outside circuit to let clamping work.

Function Description

Temperature Protection

When the junction temperature exceeds 160°C, the internal thermal sense circuit turns off the power FET and allows the device to cool down. When the device’s junction temperature cools by 40°C, the internal thermal sense circuit will enable the device, resulting in a pulsed output during continuous thermal protection. Thermal protection is designed to protect the IC in the event of over temperature conditions. For normal operation, the junction temperature cannot exceed $T_{jmax}=+125^{\circ}\text{C}$.

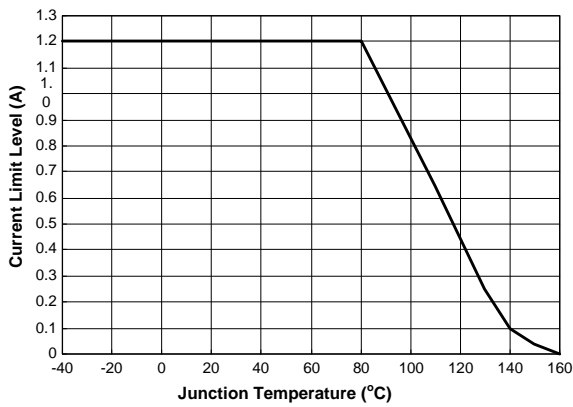

Figure 1. Current Limit vs. Junction Temperature

Application Information

Capacitor Selection

The input capacitor is for decoupling and prevents the input voltage from overshooting to dangerous levels. In the AC adapter hot plug-in applications or load current step-down transient, the input voltage has a transient spike due to the parasitic inductance of the input cable. A 25V, X5R, dielectric ceramic capacitor with a value between 1 μ F and 4.7 μ F placed close to the ACIN pin is recommended.

The output capacitor of CHR_LDO is for CHR_LDO voltage decoupling. And also can be as the input capacitor of the charging circuit. At least, a 1 μ F, 10V, X5R capacitor is recommended.

Layout Consideration

In some failure modes, a high voltage may be applied to the device. Make sure the clearance constraint of the PCB layout must satisfy the design rule for high voltage. The exposed pad of the TDFN2x2-8 and DFN3x3-8 performs the function of channeling heat away. It is recommended that connect the exposed pad to a large copper ground plane on the backside of the circuit board through several thermal vias to improve heat dissipation. The input and output capacitors should be placed close to the IC. The high current traces like input trace and output trace must be wide and short.

Recommended Minimum Footprint

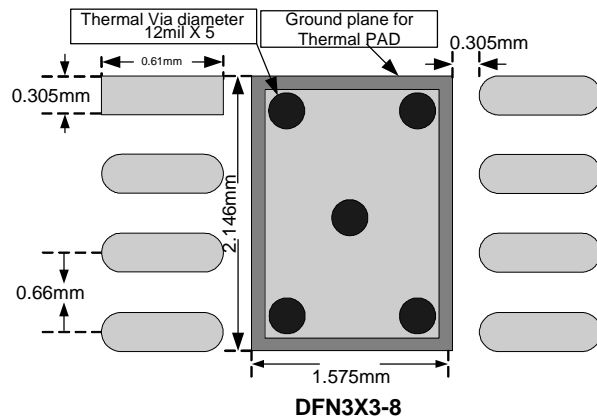
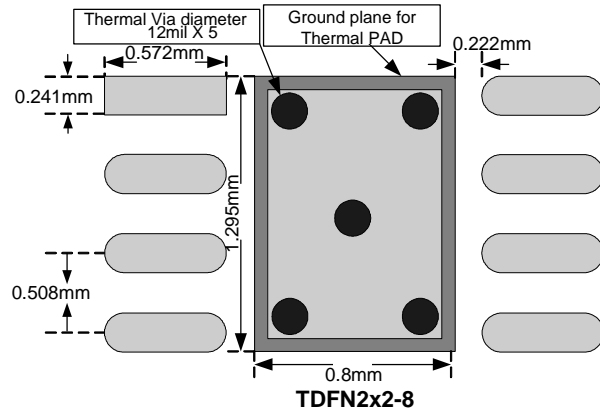

Package Information

TDFN2x2-8

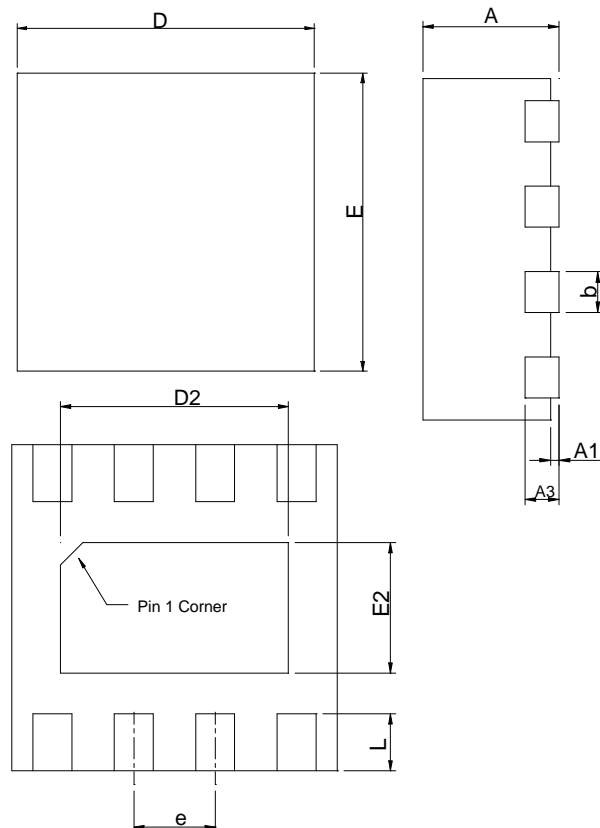

SYMBOL	TDFN2x2-8			
	MILLIMETERS		INCHES	
	MIN.	MAX.	MIN.	MAX.
A	0.70	0.80	0.028	0.031
A1	0.00	0.05	0.000	0.002
A3	0.20 REF		0.008 REF	
b	0.18	0.30	0.007	0.012
D	1.90	2.10	0.075	0.083
D2	1.00	1.60	0.039	0.063
E	1.90	2.10	0.075	0.083
E2	0.60	1.00	0.024	0.039
e	0.50 BSC		0.020 BSC	
L	0.30	0.45	0.012	0.018

Note : 1. Follow from JEDEC MO-229 WCCD-3.

Package Information

DFN3x3-8

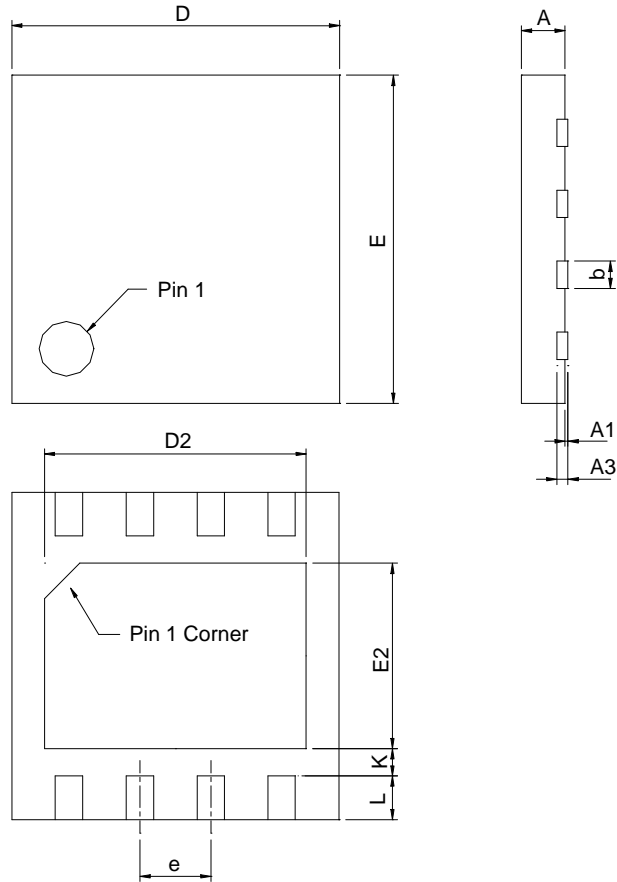

SYMBOL	DFN3x3-8			
	MILLIMETERS		INCHES	
	MIN.	MAX.	MIN.	MAX.
A	0.80	1.00	0.031	0.039
A1	0.00	0.05	0.000	0.002
A3	0.20 REF		0.008 REF	
b	0.25	0.35	0.010	0.014
D	2.90	3.10	0.114	0.122
D2	1.90	2.40	0.075	0.094
E	2.90	3.10	0.114	0.122
E2	1.40	1.75	0.055	0.069
e	0.65 BSC		0.026 BSC	
L	0.30	0.50	0.012	0.020
K	0.20		0.008	

Carrier Tape & Reel Dimensions

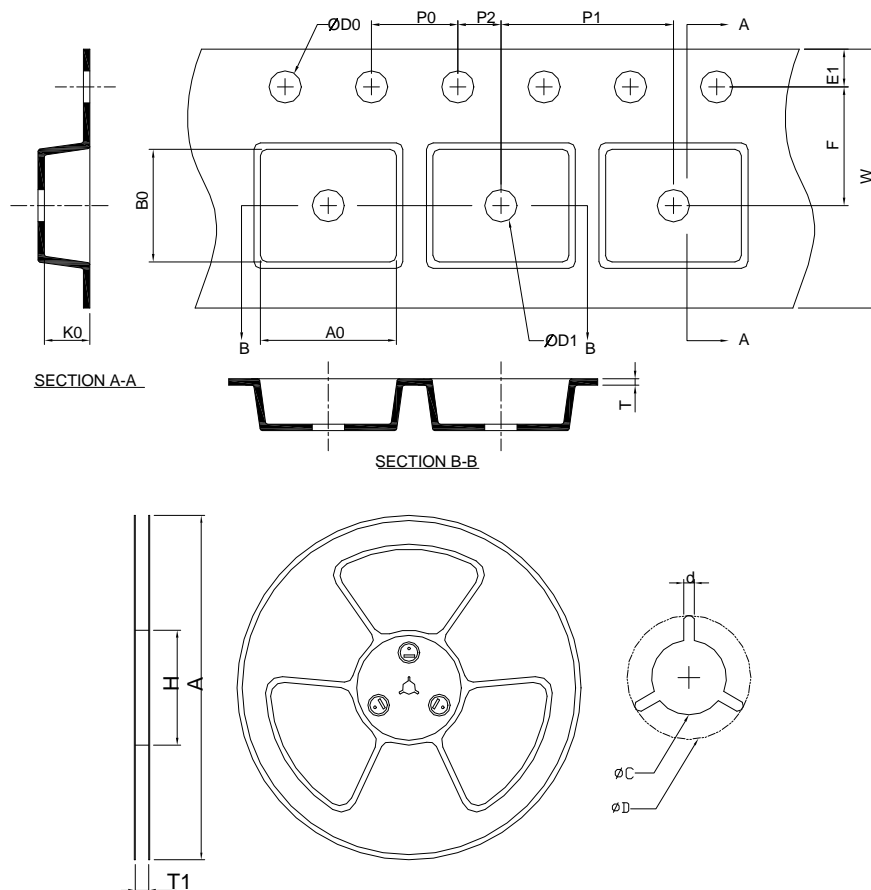

Application	A	H	T1	C	d	D	W	E1	F
TDFN2x2-8	178.0 ±2.00	50 MIN.	8.4+2.00 -0.00	13.0+0.50 -0.20	1.5 MIN.	20.2 MIN.	8.0 ±0.20	1.75 ±0.10	3.50 ±0.05
	P0	P1	P2	D0	D1	T	A0	B0	K0
	4.0 ±0.10	4.0 ±0.10	2.0 ±0.05	1.5+0.10 -0.00	1.5 MIN.	0.6+0.00 -0.4	3.35 MIN	3.35 MIN	1.30 ±0.20
Application	A	H	T1	C	d	D	W	E1	F
DFN3x3-8	178.0 ±2.00	50 MIN.	12.4+2.00 -0.00	13.0+0.50 -0.20	1.5 MIN.	20.2 MIN.	12.0 ±0.30	1.75 ±0.10	5.5 ±0.05
	P0	P1	P2	D0	D1	T	A0	B0	K0
	4.0 ±0.10	8.0 ±0.10	2.0 ±0.05	1.5+0.10 -0.00	1.5 MIN.	0.6+0.00 -0.40	3.30 ±0.20	3.30 ±0.20	1.30 ±0.20

(mm)

Devices Per Unit

Package Type	Unit	Quantity
TDFN2x2-8	Tape & Reel	3000
DFN3x3-8	Tape & Reel	3000

Taping Direction Information

TDFN2x2-8

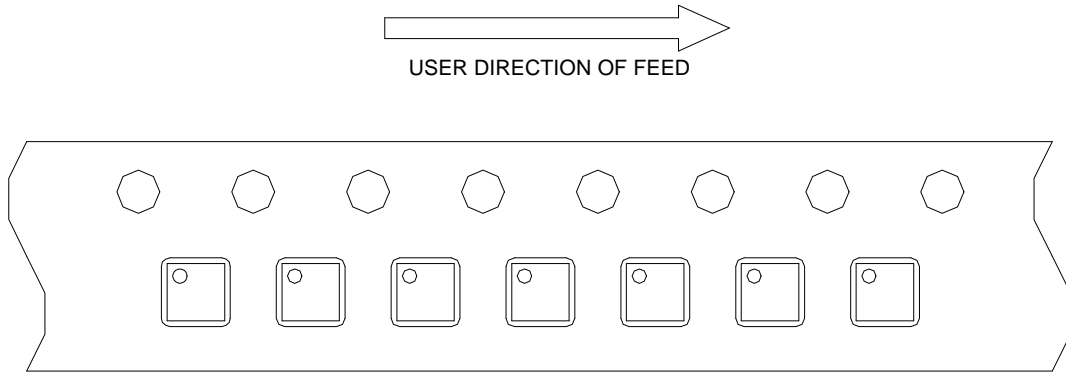

DFN3x3-8

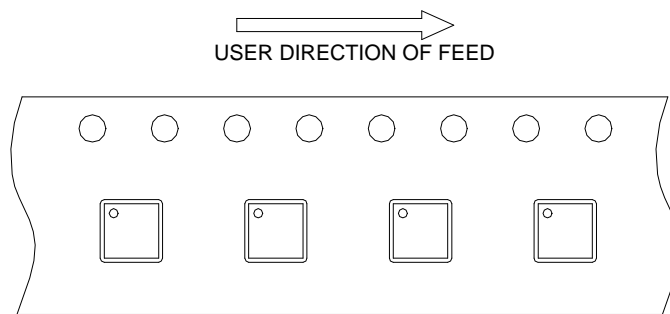

Classification Profile

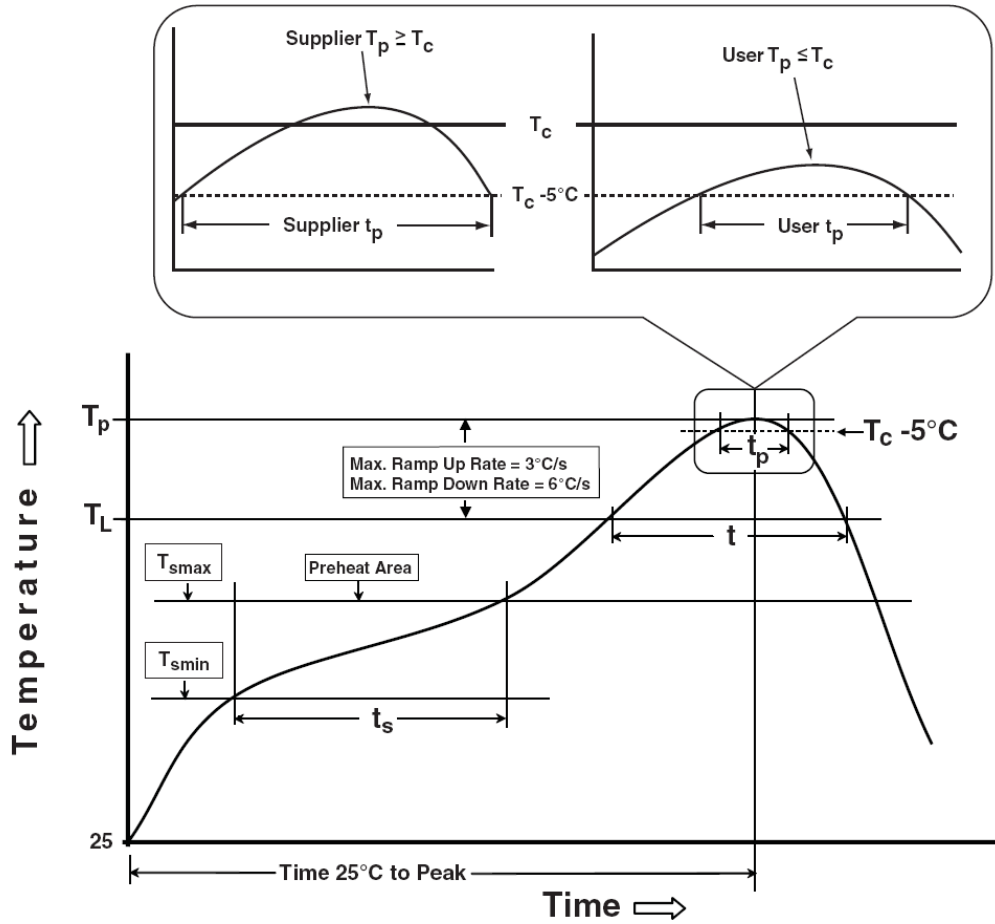

Classification Reflow Profiles

Profile Feature	Sn-Pb Eutectic Assembly	Pb-Free Assembly
Preheat & Soak		
Temperature min (T_{smin})	100 °C	150 °C
Temperature max (T_{smax})	150 °C	200 °C
Time (T_{smin} to T_{smax}) (t_s)	60-120 seconds	60-120 seconds
Average ramp-up rate (T_{smax} to T_p)	3 °C/second max.	3°C/second max.
Liquidous temperature (T_L)	183 °C	217 °C
Time at liquidous (t_L)	60-150 seconds	60-150 seconds
Peak package body Temperature (T_p)*	See Classification Temp in table 1	See Classification Temp in table 2
Time (t_p)** within 5°C of the specified classification temperature (T_c)	20** seconds	30** seconds
Average ramp-down rate (T_p to T_{smax})	6 °C/second max.	6 °C/second max.
Time 25°C to peak temperature	6 minutes max.	8 minutes max.
* Tolerance for peak profile Temperature (T_p) is defined as a supplier minimum and a user maximum.		
** Tolerance for time at peak profile temperature (t_p) is defined as a supplier minimum and a user maximum.		

Table 1. SnPb Eutectic Process – Classification Temperatures (T_c)

Package Thickness	Volume mm ³ <350	Volume mm ³ ≥350
<2.5 mm	235 °C	220 °C
≥2.5 mm	220 °C	220 °C

Table 2. Pb-free Process – Classification Temperatures (T_c)

Package Thickness	Volume mm ³ <350	Volume mm ³ 350-2000	Volume mm ³ >2000
<1.6 mm	260 °C	260 °C	260 °C
1.6 mm – 2.5 mm	260 °C	250 °C	245 °C
≥2.5 mm	250 °C	245 °C	245 °C

Reliability Test Program

Test item	Method	Description
SOLDERABILITY	JESD-22, B102	5 Sec, 245°C
HOLT	JESD-22, A108	1000 Hrs, Bias @ $T_j=125^\circ\text{C}$
PCT	JESD-22, A102	168 Hrs, 100%RH, 2atm, 121°C
TCT	JESD-22, A104	500 Cycles, -65°C~150°C
HBM	MIL-STD-883-3015.7	VHBM 2KV
MM	JESD-22, A115	VMM 200V
Latch-Up	JESD 78	10ms, 1 _{tr} 100mA

Customer Service

Anpec Electronics Corp.

Head Office :

No.6, Dusing 1st Road, SBIP,

Hsin-Chu, Taiwan, R.O.C.

Tel : 886-3-5642000

Fax : 886-3-5642050

Taipei Branch :

2F, No. 11, Lane 218, Sec 2 Jhongsing Rd.,

Sindian City, Taipei County 23146, Taiwan

Tel : 886-2-2910-3838

Fax : 886-2-2917-3838